

For teachers and groups

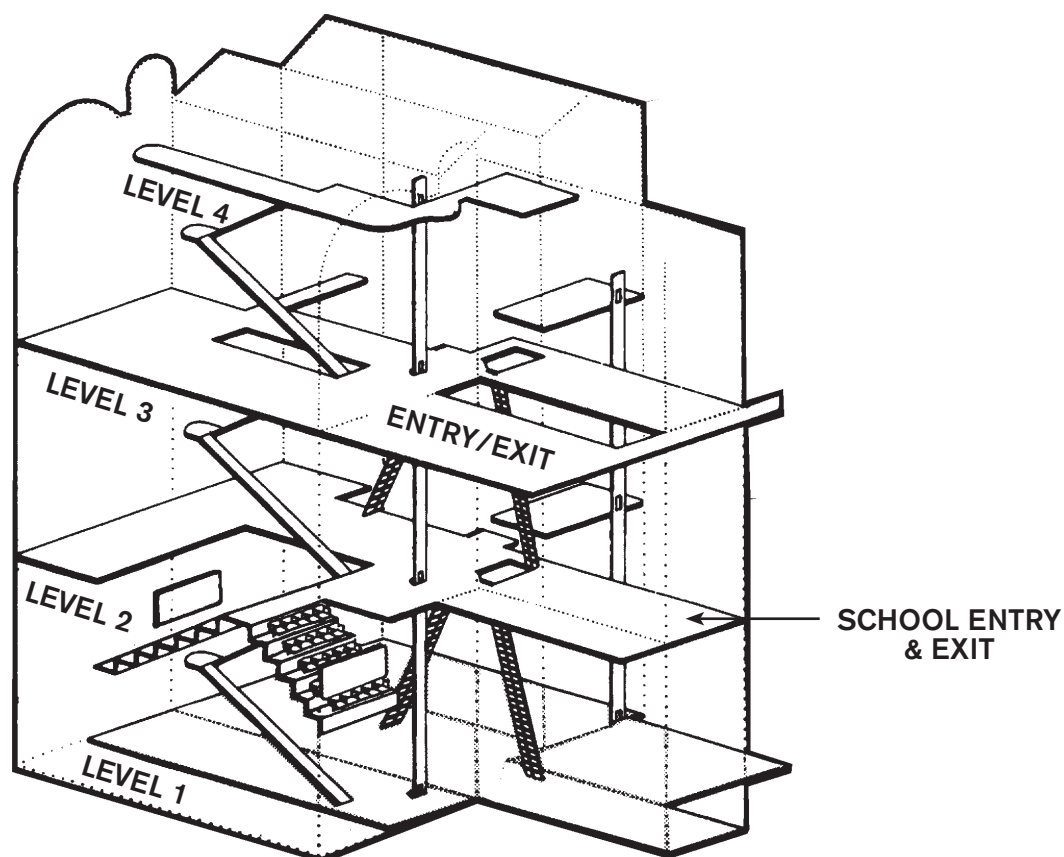

Attached are floor plans which show you where exhibitions and facilities are located, and provide information about each of the current exhibitions.

This plan shows you where you enter the building.

The Powerhouse Museum has four levels accessible to the public. You will arrive on level 2. There are two levels above (levels 3 and 4) and one below (level 1).

3

Entry/Exit
You entered here

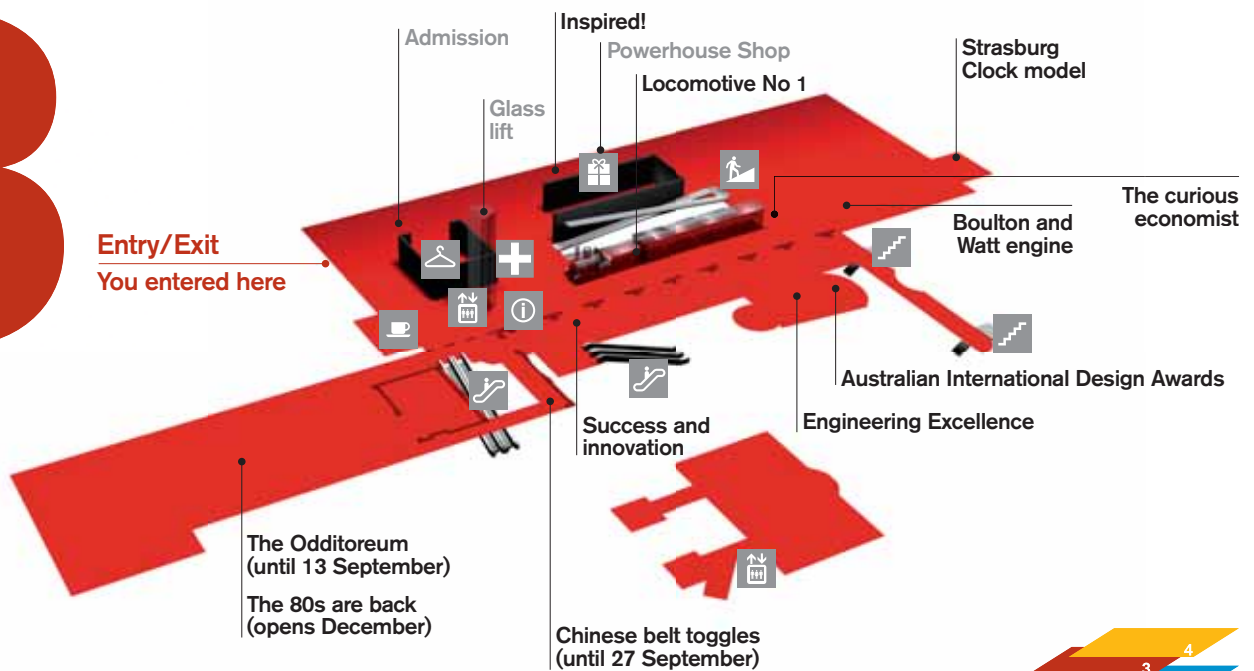

FACILITIES ON THIS LEVEL

- Cloaking
- Information
- First aid
- Powerhouse Shop
- Cafe

EXHIBITIONS ON THIS LEVEL

★ Chinese belt toggles (until 27 September)

A small display of carved ornaments traditionally used to suspend small bags from men's belts, but also items of great symbolic significance and beauty.

Inspired! Design across time

Be inspired! Fashion, furniture, textiles, glass, graphics, ceramics and metalwork spanning 300 years of decorative arts and design from the 1700s to today.

The Strasburg Clock model

Watch the Strasburg Clock model in action and hear its story. Hourly from 10.55 am – 3.55 pm.

The curious economist: William Stanley Jevons in Sydney

Photographs, journals and inventions from the intriguing life of William Stanley Jevons.

Hargrave box kites

See box kites by Australia's pioneer aviator, Lawrence Hargrave, suspended above Loco No 1.

Locomotive No 1

The locomotive that hauled NSW's first passenger train, now with an audiovisual about its history.

Success and innovation: achieving for Australia

Industrial innovation — past, present and future.

★ Engineering Excellence

Winning projects from the 2008 Engineering Excellence Awards.

★ Australian International Design Awards

The Powerhouse selection from the Australian Design Awards features outstanding achievements in design.

Boulton and Watt engine

A lasting reminder of the Industrial Revolution.

PROGRAM

★ The Odditorem (until 13 September)

A small display of weird, wonderful and wacky objects from deep within the Museum vaults. Featuring imaginative labels written by celebrated author Shaun Tan.

★ = new or refurbished exhibitions

Level 2: school, group and after-hours entrance

2

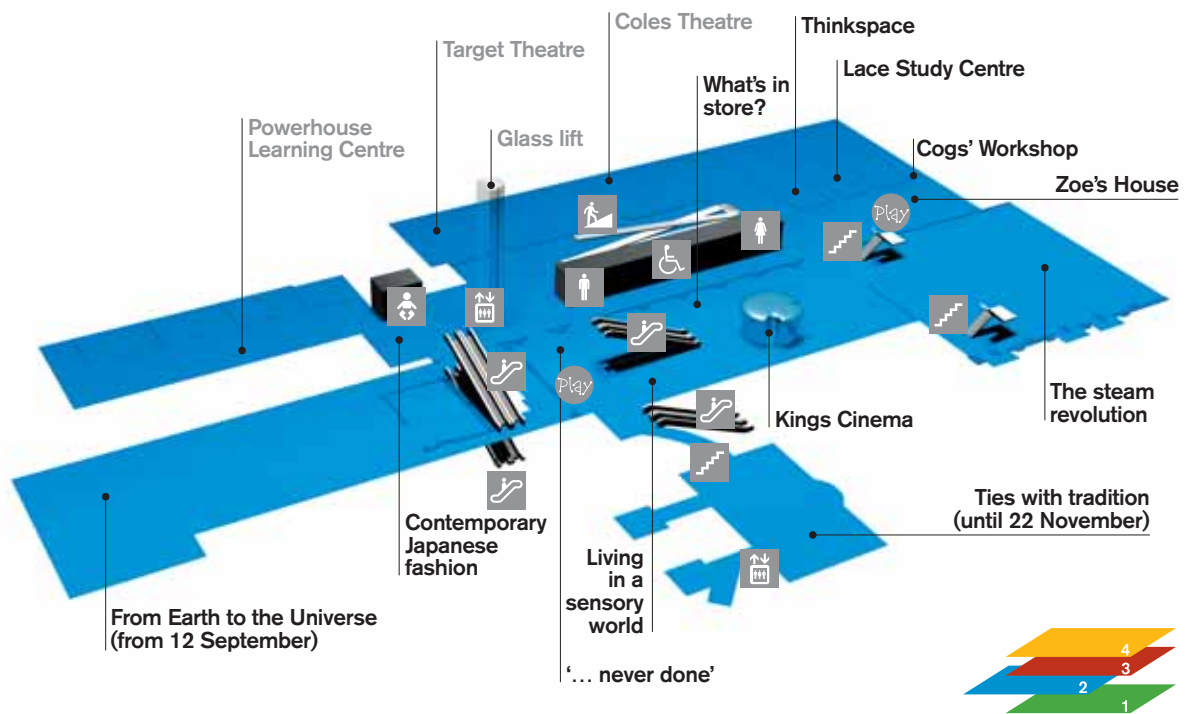

FACILITIES ON THIS LEVEL

- Powerhouse Learning Centre
- Thinkspace
- Lace Study Centre
- Theatres (performances and functions)
- Baby change room

EXHIBITIONS ON THIS LEVEL

★ From Earth to the Universe (from 12 September)

Celebrating the International Year of Astronomy, this exhibition reveals the mysteries of the Universe with spectacular images of the solar system, the Milky Way and beyond.

★ Ties with tradition: Macedonian apron designs

(until 22 November)
A powerful juxtaposition of colour and patterns.

★ Contemporary Japanese fashion: the Gene Sherman collection

Gene Sherman is a noted connoisseur, collector and wearer of sometimes extreme fashion by leading Japanese designers. *Contemporary Japanese fashion* features garments by Issey Miyake, Comme des Garçon and Yohji Yamamoto.

What's in store? Shopping in Australia 1880–1930

Looks at the development of shops in Australia — from the small country store to big city department stores.

'... never done': women's work in the home

The hidden history of the daily work of women, focusing on an 1880s bush hut kitchen and a 1920s kitchen.

The Kings Cinema

Take a seat inside our 1930s art deco cinema and enjoy films relating to our exhibitions.

★ Living in a sensory world: stories from people with blindness and low vision

Featuring historic objects, compelling first-hand accounts and the latest technologies for people with blindness and low vision.

The steam revolution

Discover how steam revolutionised the world. This exhibition is full of working objects, steam-powered from natural gas supplies in our basement (at selected times of the day and subject to the availability of steam).

KIDS at home

Looks at domestic activities relating to children's play in the past.

Zoe's House

An unfinished house awaits, surrounded by tools for budding builders — a crane, conveyor belt, rubble chute, rail network, wheel barrows, lifts, even hard hats and jackets. So kids, roll up your sleeves and start building Zoe's House, an installation encouraging cooperative and creative play for 3–6 years olds. Free with Museum admission. Bookings for groups essential during term time on (02) 9217 0222.

Thinkspace

Expand your mind and explore the latest art, music and video production tools! Courses to develop your digital media skills are now available. Visit website (www.powerhousemuseum.com/thinkspace) for workshop details and bookings.

★ = new exhibitions

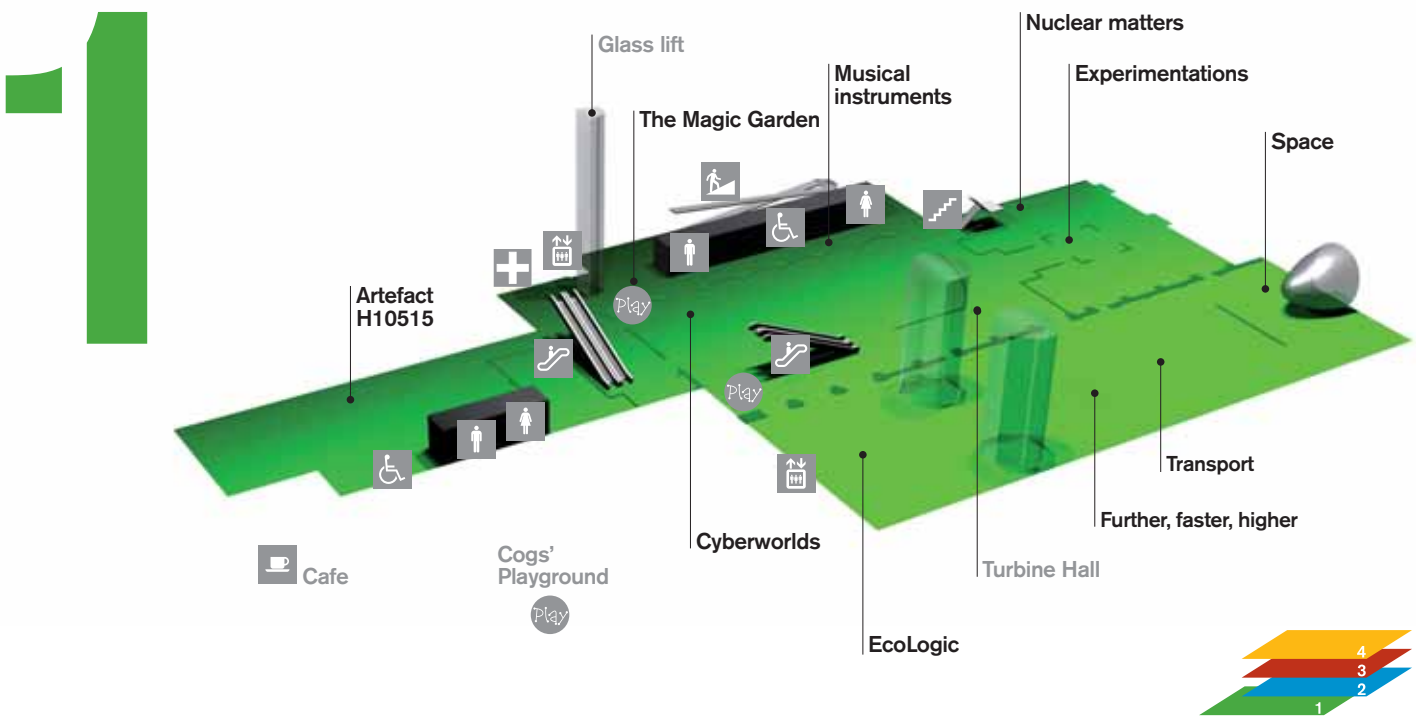

FACILITIES ON THIS LEVEL

- First aid
- Courtyard Cafe
- Cogs' Playground
- Toilets

EXHIBITIONS ON THIS LEVEL

★ Artefact H10515

Created in collaboration with artist Craig Walsh, *Artefact H10515* is the Museum's unique 'living' acquisition that explores the diverse ways we source, shape and present collections. You can interact with *Artefact H10515* by uploading your own collections online.

EcoLogic: creating a sustainable future

An exhibition about the way we use resources and how clever ideas and design can reduce our impact on the planet.

Cyberworlds: computers and connections

A dynamic, interactive exhibition exploring the past, present and future uses of computers. The latest virtual reality experience, the internet, robotics and more.

Beta Space

Interact with new art and technology in the *Cyberworlds* exhibition.

Experimentations

See science in action and discover by doing.

Nuclear matters

Find out about the science of the nucleus and discover how sub-atomic particles can be used in many ways from power generation to medical treatment and diagnosis. In *Experimentations*.

Chemical attractions

Discover the processes that occur in making and perfecting many everyday items. In *Experimentations*.

Musical instruments

Some of the best and most important instruments from the Museum's collection.

Transport

Find out how transport has shaped our lives! See the enormous Catalina flying boat and 'drive' Locomotive 1243.

Further, faster, higher: a sound and light experience

Unlike anything ever seen at the Powerhouse before, this sound and light show brings to life some of the Museum's most iconic objects in the Transport Gallery.

★ Space

Step into a new space experience and discover what it's like to live on the International Space Station. The *Space* exhibition now includes the amazing Zero Gravity Space Lab, where you will experience the illusion of weightlessness.

★ The Magic Garden: MBF Foundation Healthy Kids Unit

Learn about healthy eating and healthy activity while having fun with this interactive unit. The Magic Garden is an imaginative environment, developed in consultation with health experts, where 2–8 year olds can play among pumpkins and mushrooms, chase fish in a digital pond or catch butterflies at the garden gate.

KIDS music

Aims to stimulate children's interest in music.

Cogs' Playground

Our outdoor playground area near the Courtyard Cafe (adult supervision required).

★ = new or refurbished exhibitions

4

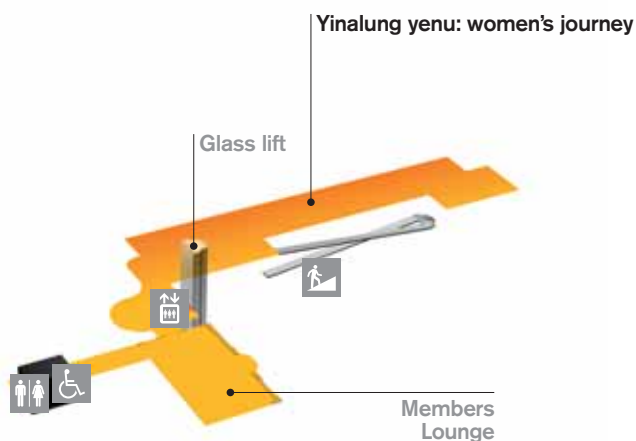
**FACILITIES ON THIS LEVEL**

- Members Lounge
Open to members and their guests only.

EXHIBITIONS ON THIS LEVEL**★ Yinalung yenu: women's journey**

Indigenous women share their stories and reveal the many roles they've played in Australian society, from traditional times to today.

★ = new exhibitions

We recommend that you allow at least half an hour for each exhibition. If you require more extensive notes on any of these exhibitions please contact our bookings office.

Phone: (02) 9217 0222

Email: edserv@phm.gov.au

Fax: (02) 9217 0441 Internet: www.powerhousemuseum.com